



MULTI-VERTICAL AFFILIATE CONFERENCE
16-17 APRIL, 2025 / WARSAW, POLAND

CONVERSION CONF



CONVERSION CONF

CONVERSION CLUB ALWAYS PRIORITIZES PROVIDING HIGH-QUALITY EXPERIENCES FOR OUR ATTENDEES. OUR FRIENDS AND PARTNERS HAVE ALREADY MADE COUNTLESS VALUABLE CONNECTIONS AT OUR MEETUPS, AND NOW WE ARE EXCITED TO TAKE IT EVEN FURTHER WITH THE UPCOMING CONVERSION CONF IN POLAND.

ARE YOU INTERESTED IN ATTENDING THE CONFERENCE?

WE'D LOVE TO SEE YOU AT CONVERSION CONF IN POLAND.

WHEN: 16-17 APRIL, 2025

WHERE: EXPO XXI, WARSAW, POLAND.

THE CONVERSION CONF IS FOR THE WORLD'S TOP AFFILIATE MARKETERS AND INDUSTRY GURUS.

CHOOSE YOUR SPONSORSHIP BELOW!

GENERAL INFO

CONVERSION CONF CREATES HIGH-QUALITY NETWORKING AND PROVIDES ALL OUR PARTNERS WITH POWERFUL INTRODUCTIONS AND PROMOTIONS.

2000 VISITORS

50 SPEAKERS

5 VERTICALS

VERTICALS



NUTRA



FINANCE



DATING



E-COMMERCE



IGAMING



GAMING



CONFERENCE MAP

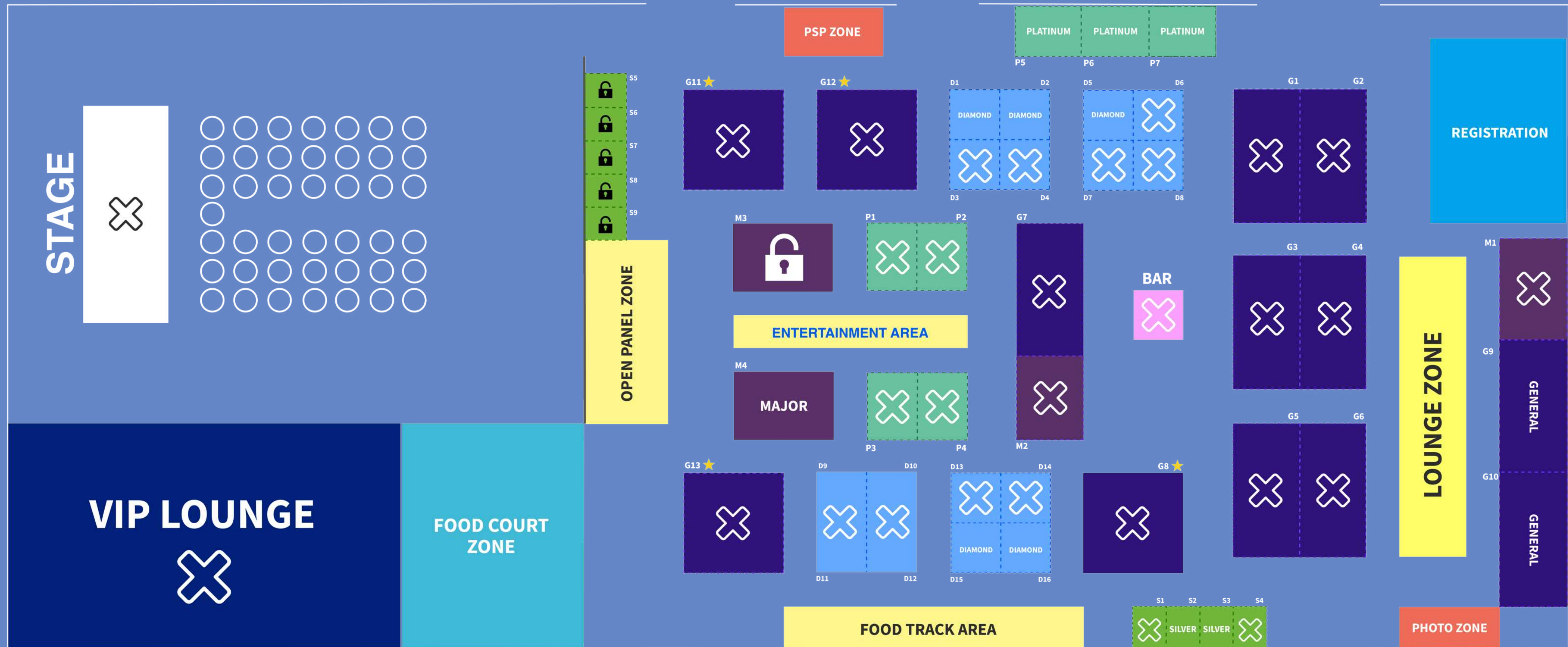

GENERAL PLUS

GENERAL PLUS

USD 30000

WHAT does this package offer?

- 10 diamond tickets for the team including diamond access to the afterparty
- 6 silver tickets for affiliates
- 36 m2 of your space (6x6 m)
Individual construction of 36 m2 booth, according to your desired specifications and at your expense)
- Prominent placement in one of the most visible areas at the conference venue
- Your Logo on the Stages screens during speeches*
- Opportunity to host the exhibition activities upon request +30-minute speech slot (must be booked two months in advance)
- Translation support available upon your request
- Logos on the press wall of the photozone
- Opportunity to host a Giveaway on stage**
- Model accreditation (where you bring your own promo models and we provide passes for them during the conference)

- The opportunity to bring your own roll-up banners to the conference venue and print it yourself
- 1 exclusive email newsletter with a description of your brand
- Watermarked photos with your logo after the conference
- Company logo in the top categories of the conference sponsors
- Sponsorship announcement on the conference website + social media (audience of 60K+ marketers)

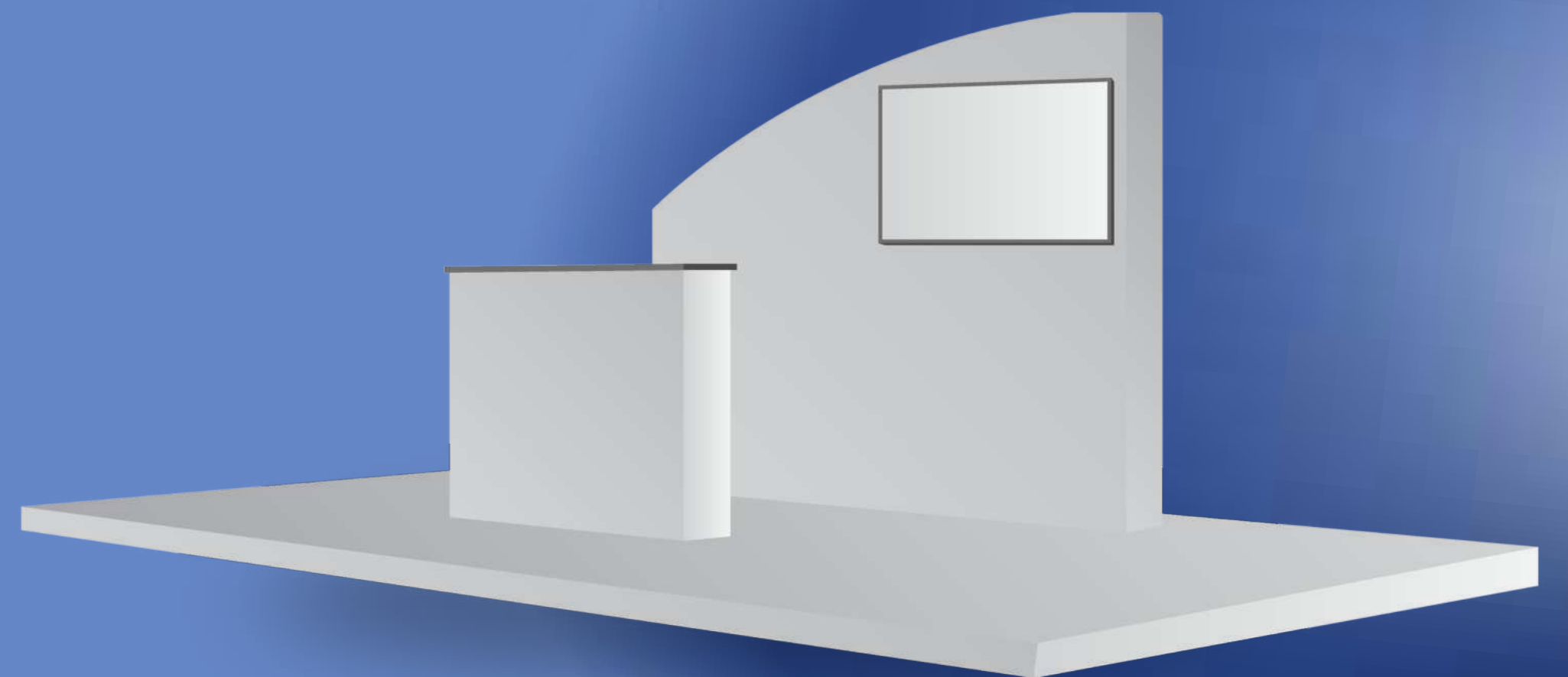

GENERAL SPONSOR

USD 25000

WHAT does this package offer?

- 12 diamond tickets for the team including diamond access to the afterparty
- 6 silver tickets for affiliates
- 32 m2 of your space (8x4 m)
- Backwall 6 meters wide with led lamps
- LED screen 2x2,5 m at the booth area branded only with your visuals
- 4 Sofas & 2 Coffee Tables
- 1 branded table stand
- 3 high chairs
- Your Logo on the Stages screens during speeches*
- Prominent placement in one of the most visible areas at the conference venue
- Opportunity to host the exhibition activities upon request
- +30-minute speech slot (must be booked two months in advance)
- Model accreditation (where you bring your own promo models and we provide passes for them during the conference)

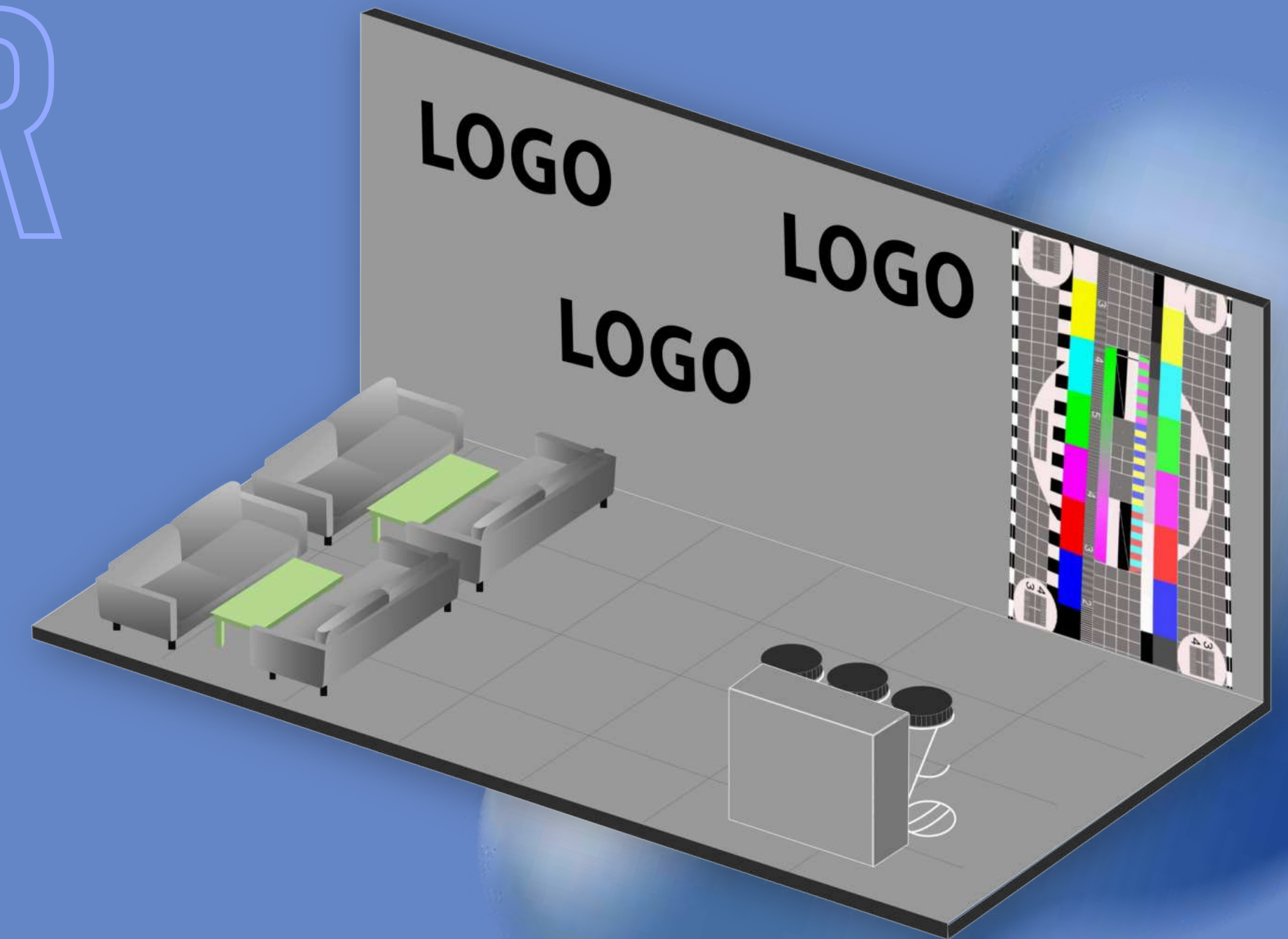

- Translation support available upon your request
- Logos on the press wall of the photozone
- Opportunity to host a Giveaway on stage**
- 1 exclusive email newsletter with a description of your brand
- The opportunity to bring your own roll-up banners to the conference venue and print it yourself
- Watermarked photos with your logo after the conference
- Company logo in the top categories of the conference sponsors
- Sponsorship announcement on the conference website + social media (audience of 60K+ marketers)

Interested? Contact us right now!

* static logo/text goes for 15 sec on the screens ** ask the sales manager for details about the Giveaway

* Booking deadlines: 20 days before the event * Design deadlines: 15 days before the event

EXCLUSIVE GENERAL SPACE SPONSOR

EXCLUSIVE GENERAL SPACE SPONSOR

USD 19900

WHAT does this package offer?

- 10 diamond tickets for the team including diamond access to the afterparty
- 6 silver tickets for affiliates
- 32 m2 of your space (8x4 m)
Individual construction of 32 m2 booth, according to your desired specifications and at your expense)
- Prominent placement in one of the most visible areas at the conference venue
- Your Logo on the Stages screens during speeches*
- Opportunity to host the exhibition activities upon request
- +30-minute speech slot (must be booked two months in advance)
- Translation support available upon your request
- Logos on the press wall of the photozone
- Opportunity to host a Giveaway on stage**
- Model accreditation (where you bring your own promo models and we provide passes for them during the conference)
- The opportunity to bring your own roll-up banners to the conference venue and print it yourself
- 1 exclusive email newsletter with a description of your brand
- Watermarked photos with your logo after the conference
- Company logo in the top categories of the conference sponsors
- Sponsorship announcement on the conference website + social media (audience of 60K+ marketers)

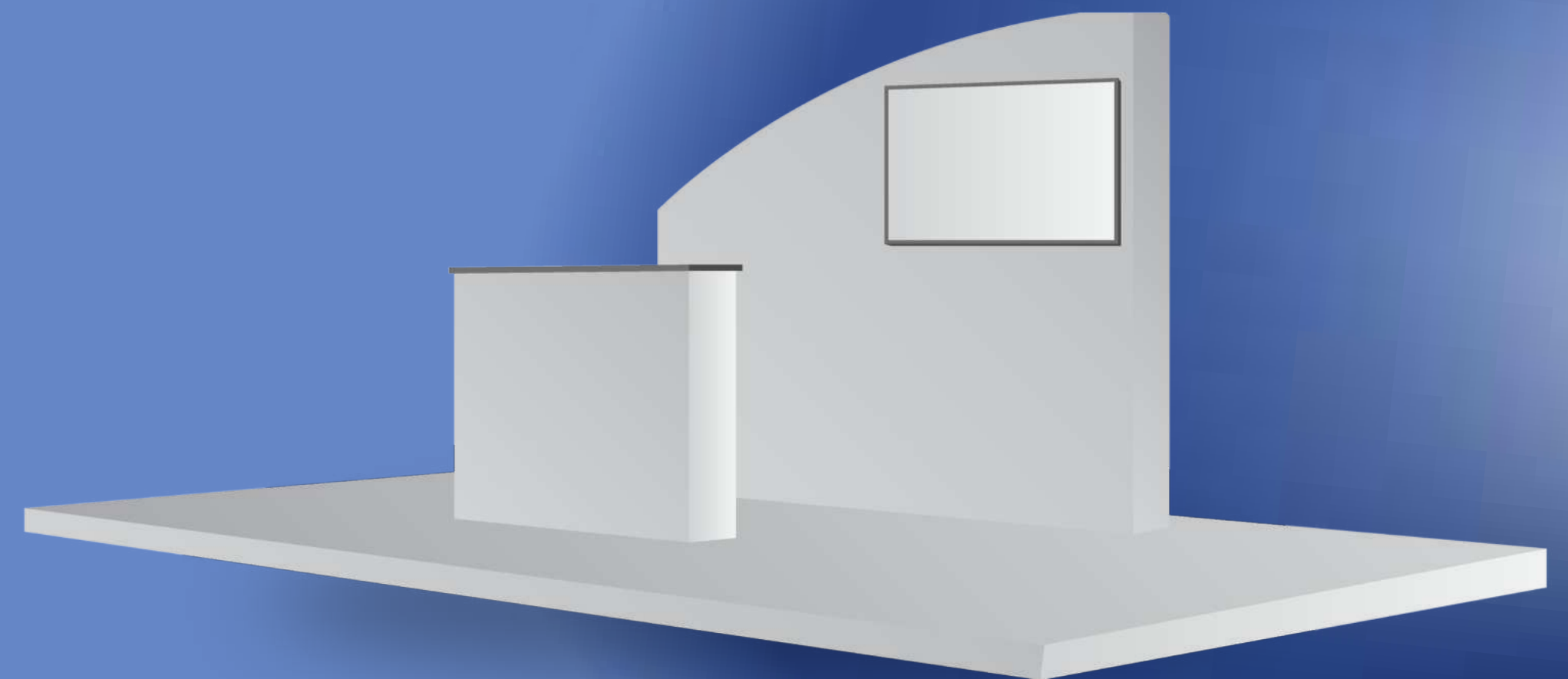

MAJOR SPONSOR

USD 17600

WHAT does this package offer?

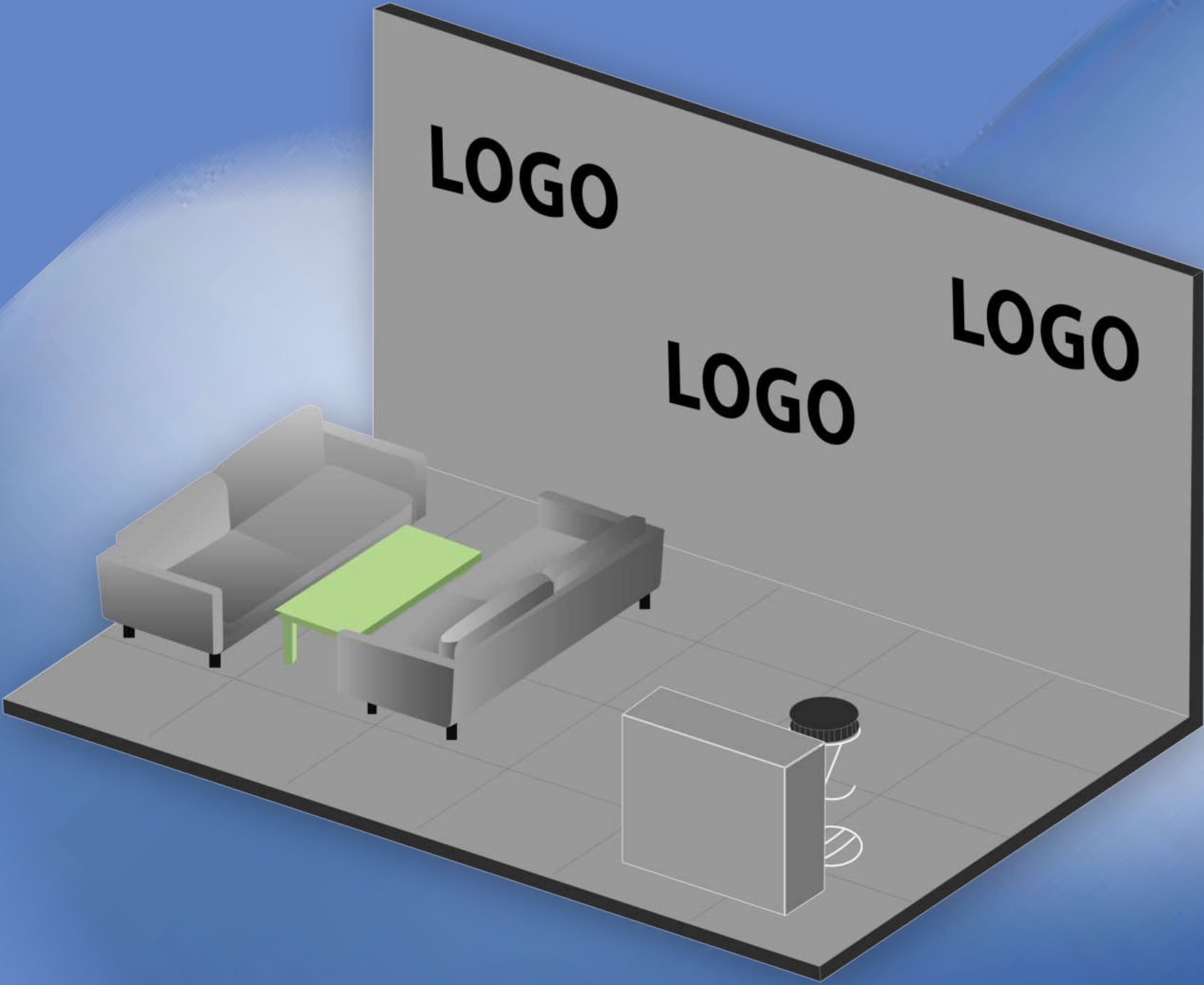
- 10 diamond tickets for the team including diamond access to the afterparty
 - 4 silver tickets for affiliates
 - 24 m2 of your space (6x4 m)
 - Backwall 6 meters wide with led lamps
 - Prominent placement in one of the most visible areas at the conference venue
 - 2 Sofas & 1 Coffee Table
 - 1 branded table stand and a high chair
 - Opportunity to host the exhibition activities upon request
 - +30-minute speech slot (must be booked two months in advance)
 - Translation support available upon your request
 - Logos on the press wall of the photozone
 - Opportunity to set up an LED screen (additional charges apply)
 - Opportunity to host a Giveaway on stage**
- 
- Model accreditation (where you bring your own promo models and we provide passes for them during the conference)
 - The opportunity to bring your own roll-up banners to the conference venue and print it yourself
 - Sponsorship announcement on conference website + social media (audience of 60K+ marketers)

EXCLUSIVE MAJOR SPACE SPONSOR

EXCLUSIVE MAJOR SPACE SPONSOR

USD 14400

WHAT does this package offer?

- 8 diamond tickets for the team including diamond access to the afterparty
- 4 silver tickets for affiliates
- 24 m2 of your space (6x4 m)
- Individual construction of 24 m2 booth, according to your desired specifications and at your expense)
- Prominent visibility in prime areas of the venue
- Opportunity to host the exhibition activities upon request
- +30-minute speech slot (must be booked two months in advance)
- Translation support available upon your request
- Logos on the press wall photo zone
- Model accreditation (where you bring your own promo models and we provide passes for them during the conference)
- The opportunity to bring your own roll-up banner to the conference venue and print it yourself
- Opportunity to host a Giveaway on stage**
- Sponsorship announcement on conference website + social media (audience of 60K+ marketers)

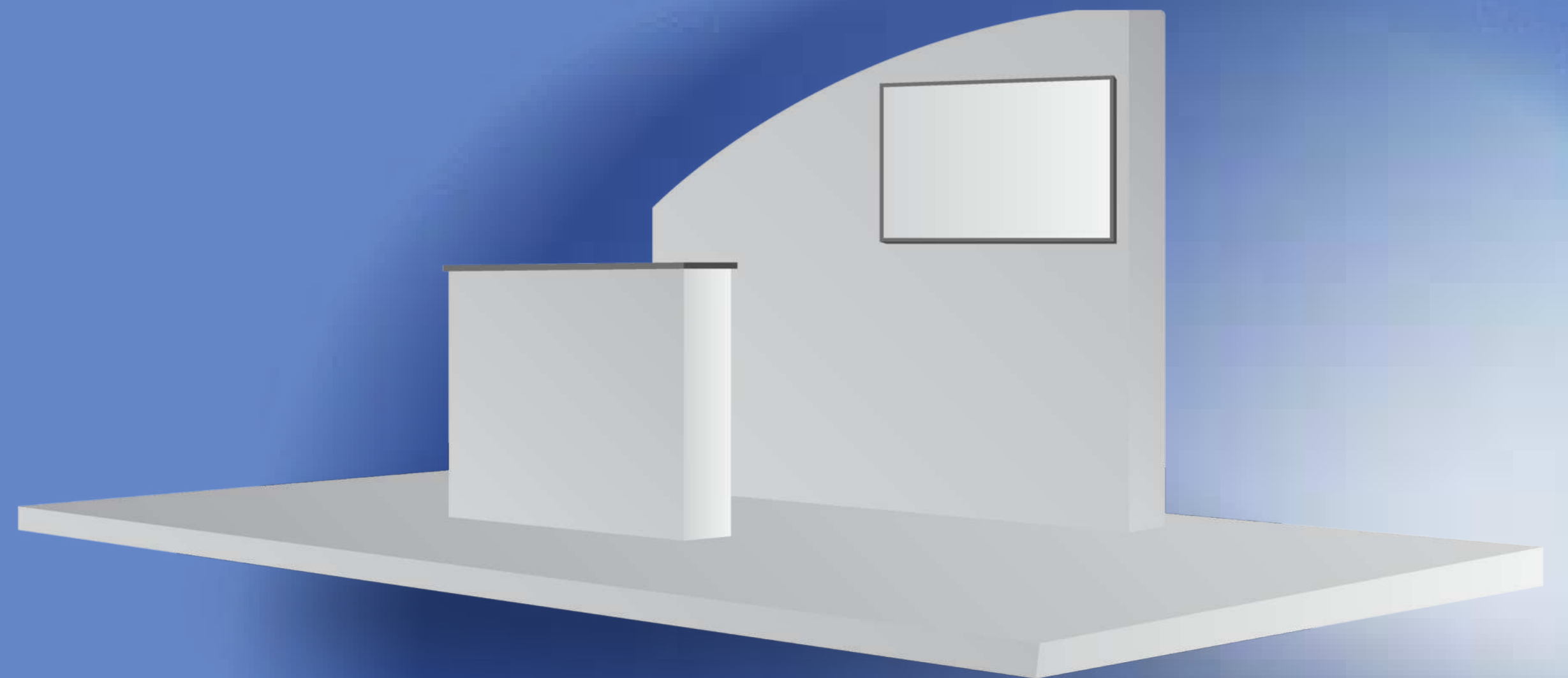

PLATINUM SPONSOR

PLATINUM SPONSOR

USD 10900

WHAT does this package offer?

- 6 gold tickets for the team including gold access to the afterparty
- 2 silver tickets for affiliates
- 12 m2 of your space (4x3 m)
- Backwall 4 meters wide with led lamps
- 2 Sofas & 1 Coffee Table
- 1 branded table stand
- 2 high chairs
- Opportunity to set up an LED screen (additional charges apply)
- The opportunity to bring your own roll-up banner to the conference venue and print it yourself
- Logos on the press wall of the photozone
- Sponsorship announcement on the conference website + social media (audience of 60K+ marketers)
- Model accreditation (where you bring your own promo models and we provide passes for them during the conference)

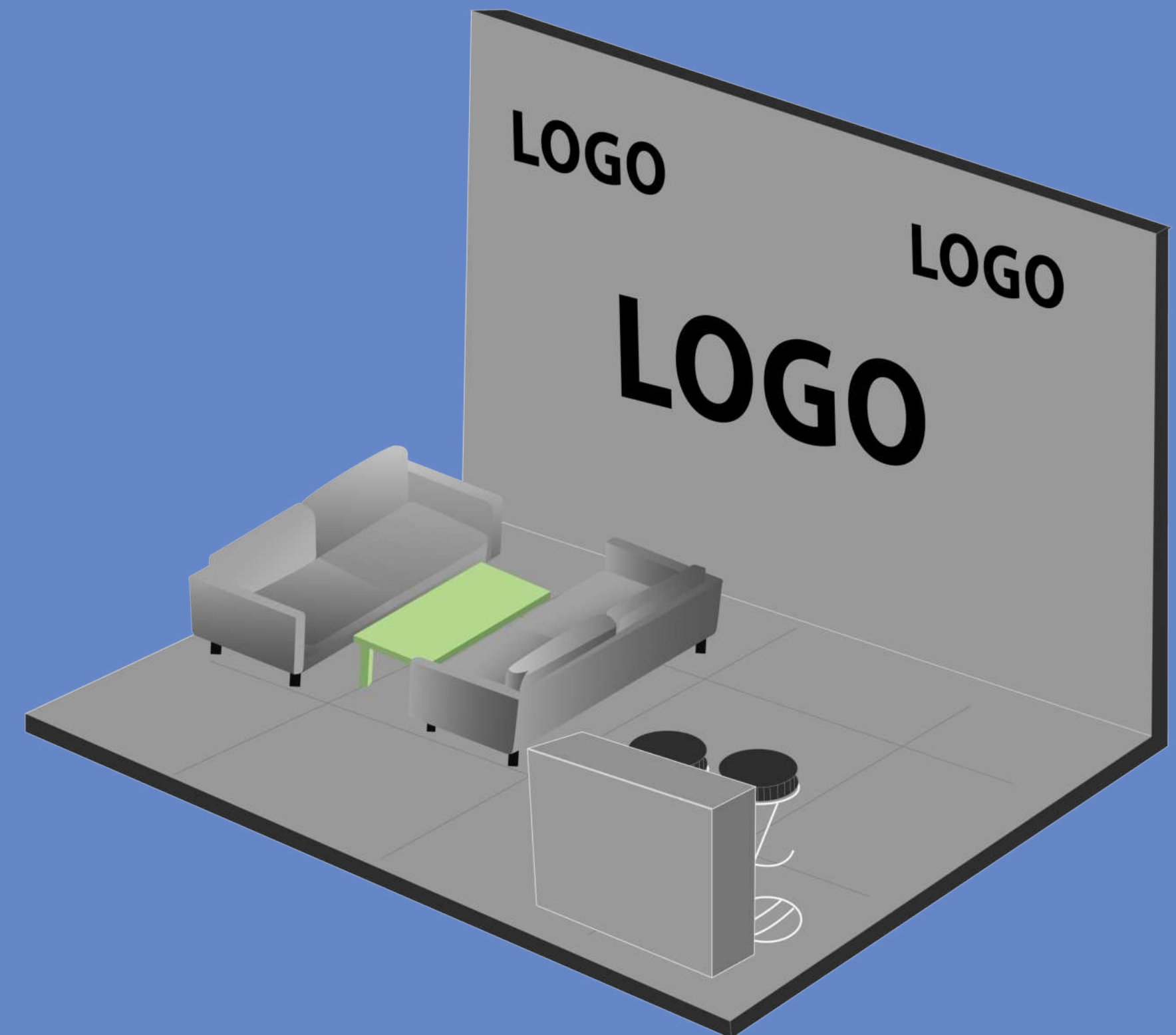

EXCLUSIVE PLATINUM SPACE SPONSOR

EXCLUSIVE PLATINUM SPACE SPO

USD 7200

WHAT does this package offer?

- 6 gold tickets for the team including gold access
- to the afterparty
- 2 silver tickets for affiliates
- 12 m2 of your space (4x3 m)
- Individual construction of 12 m2 booth according to your desired specifications and at your expense)
- Model accreditation (where you bring your own promo models and we provide passes for them during the conference)
- The opportunity to bring your own roll-up banner to the conference venue and print it yourself
- Logos on the press wall of the photozone
- Sponsorship announcement on the conference website + social media (audience of 60K+ marketers)

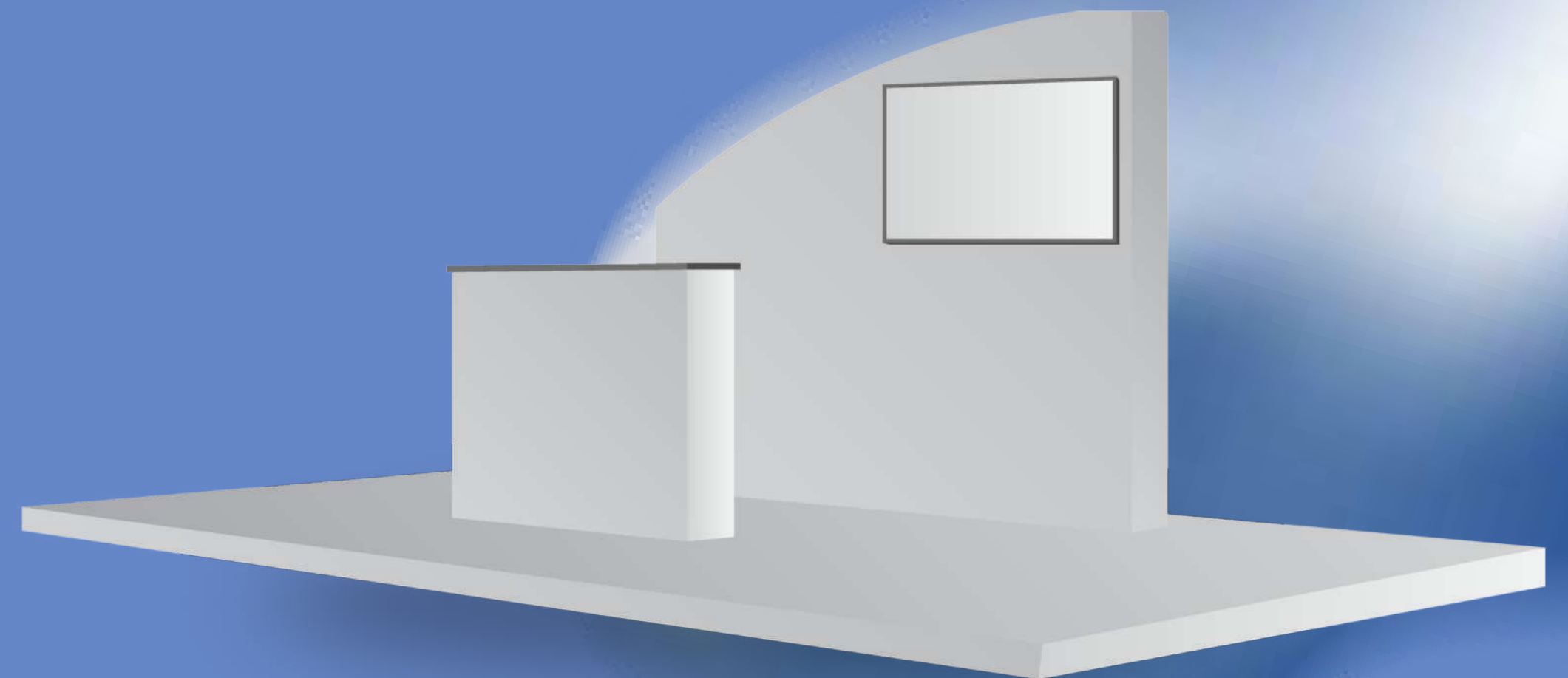

DIAMOND SPONSOR

DIAMOND SPONSOR

USD 7900

WHAT does this package offer?

- 6 gold tickets for the team including gold access to the afterparty
- 3 silver passes for affiliates
- 9 m2 of your space (3x3 m)
- Backwall 3 meters wide with LED lamps
- 1 branded table stand and a high chair
- The opportunity to bring your own roll-up banner to the conference venue and print it yourself
- Logos on the press wall of the photozone
- Sponsorship announcement on the conference website + social media (audience of 60K+ marketers)

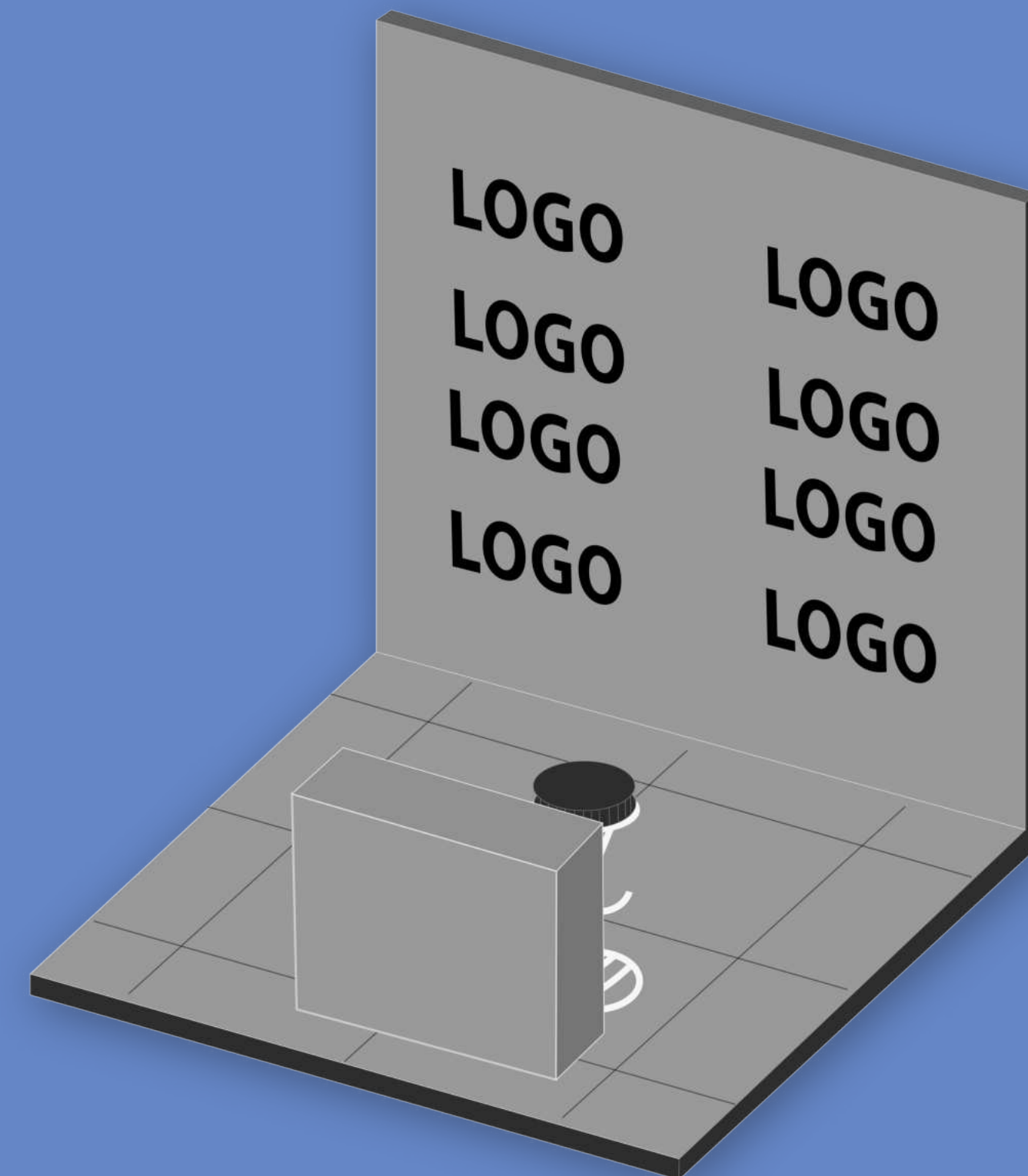

SILVER SPONSOR

USD 4500

WHAT does this package offer?

- 3 gold tickets for the team including gold access to the afterparty
- 2 silver passes for affiliates
- 5 m² of your space (2x2,5 m)
- Backwall 2 meters wide with LED lamps
- 1 branded table stand and a high chair
- Logos on the press wall of the photozone
- Sponsorship announcement on the conference website + social media (audience of 60K+ marketers)

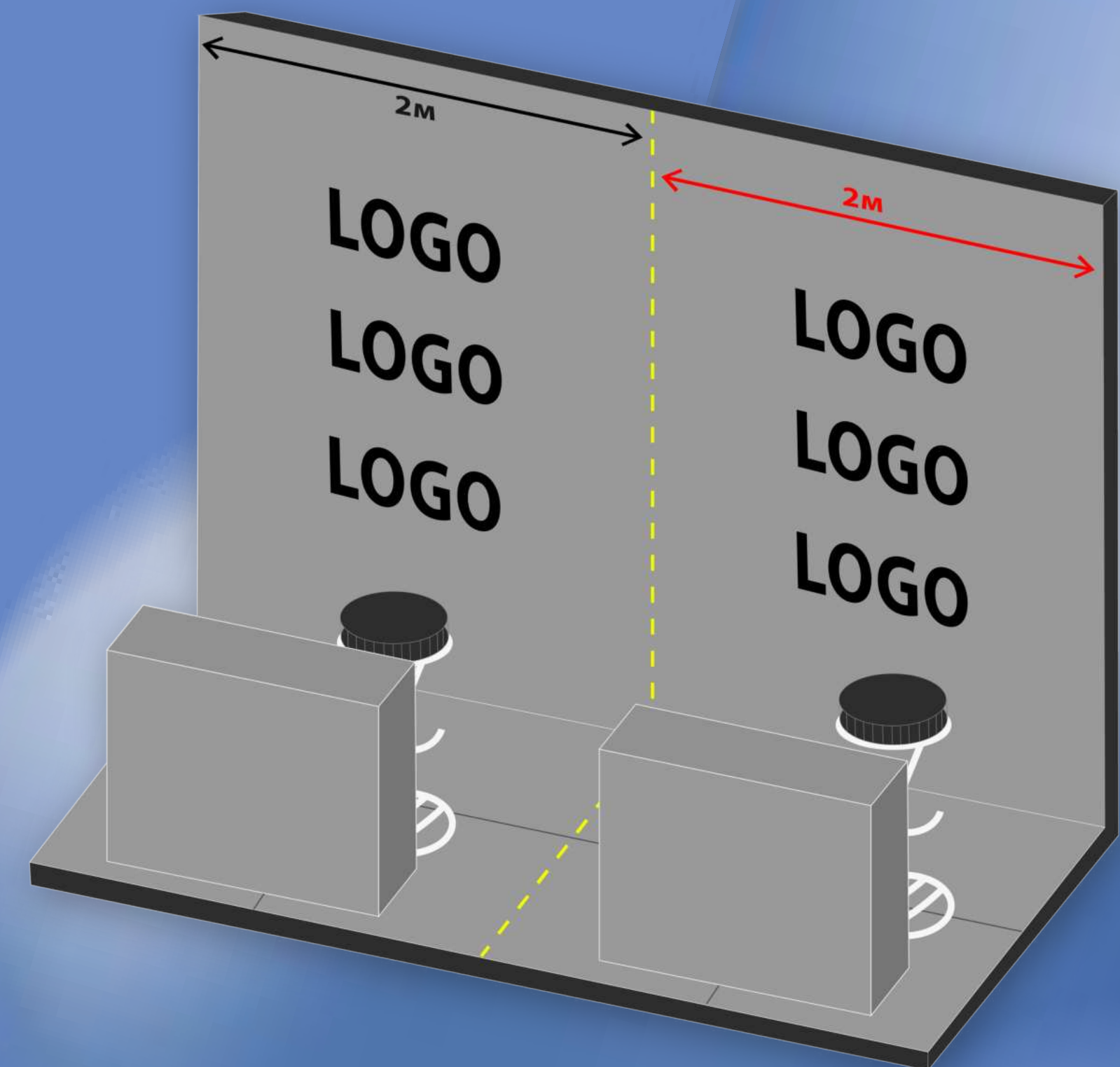

BRANDED SPEECH ZONE

USD 11900

WHAT does this package offer?

- 6 gold tickets for the team including gold access to the afterparty
- 2 silver passes for affiliates
- Branded speech stage on the left and right sides
- Branded chairs with your logo at the speech zone
- Ads TV at the speech zone
- Logos on the press wall of the photozone
- Sponsorship announcement on the conference website + social media (audience of 60K+ marketers)



MAIN BIG BOARD SPONSOR

MAIN BIG BOARD SPONSOR

USD 11999

WHAT does this package offer?

- 6 gold tickets for the team including gold access to the afterparty
- 2 silver passes for affiliates
- Branded billboard of 400 square meters in front of the conference entrance (31 meters wide, 5.2 meters high) featuring your company's logo prominently.
- Logos on the press wall of the photozone
- Sponsorship announcement on the conference website + social media (audience of 60K+ marketers)



BAR SPONSOR

BAR SPONSOR

USD 7900



SOLD OUT

WHAT does this package offer?

- 5 gold tickets for the team including gold access to the afterparty
- 2 silver passes for affiliates
- Branded bar with big vinyl banners
- T-shirts with your logo for 2 bartenders
- 200 coasters and 200 business cards distributed throughout the location
- Logos on the press wall of the photozone
- Sponsorship announcement on the conference website + social media (audience of 60K+ marketers)

BRANDED RECEPTION

BRANDED RECEPTION

USD 7900



WHAT does this package offer?

- 5 gold tickets for the team including gold access to the afterparty
- 2 silver passes for affiliates
- Branded registration counter
- 2 fly banners with your logo
- Logos on the press wall
- Sponsorship announcement on the conference website + social media (audience of 60K+ marketers)

BAGS SPONSOR

USD 7900



WHAT does this package offer?

- 5 gold tickets for the team including gold access to the afterparty
- 2 silver passes for affiliates
- Branded bags with merch for attendees of the Conference
- Logos on the press wall of the photozone
- Sponsorship announcement on conference website + social media (audience of 60K+ marketers)

PHOTOZONE SPONSOR

PHOTOZONE SPONSOR

USD 8000

(Individual construction of photozone, according to your desired specifications and at your expense)

USD 6000



WHAT does this package offer?

- 3 gold tickets for the team including gold access to the afterparty 2 silver passes for affiliates;
- Branded Brand Wall with 6x2,5 m at the Conference Sponsorship announcement on the conference website + social media (audience of 60K+ marketers).

BRACELET SPONSOR

BRACELET SPONSOR

USD 6900

WHAT does this package offer?

- 4 gold tickets for the team including gold access to the afterparty
 - 2 silver passes for affiliates
 - Branded bracelets for all attendees of the Conference
 - Logos on the press wall
- Sponsorship announcement on the conference website + social media (audience of 60K+ marketers)



OPEN SPEECH PANEL SPONSOR

USD 6900

WHAT does this package offer?

- 4 gold tickets for the team including gold access to the afterparty
- 2 silver passes for affiliates
- Your logo on video translation on a 3x4 meter LED-screen during conference and between speakers' reports
- Branded banner on the stage 1x4 m
- Logos on Press Wall
- Sponsorship announcement on conference website + social media (audience of 60K+ marketers)

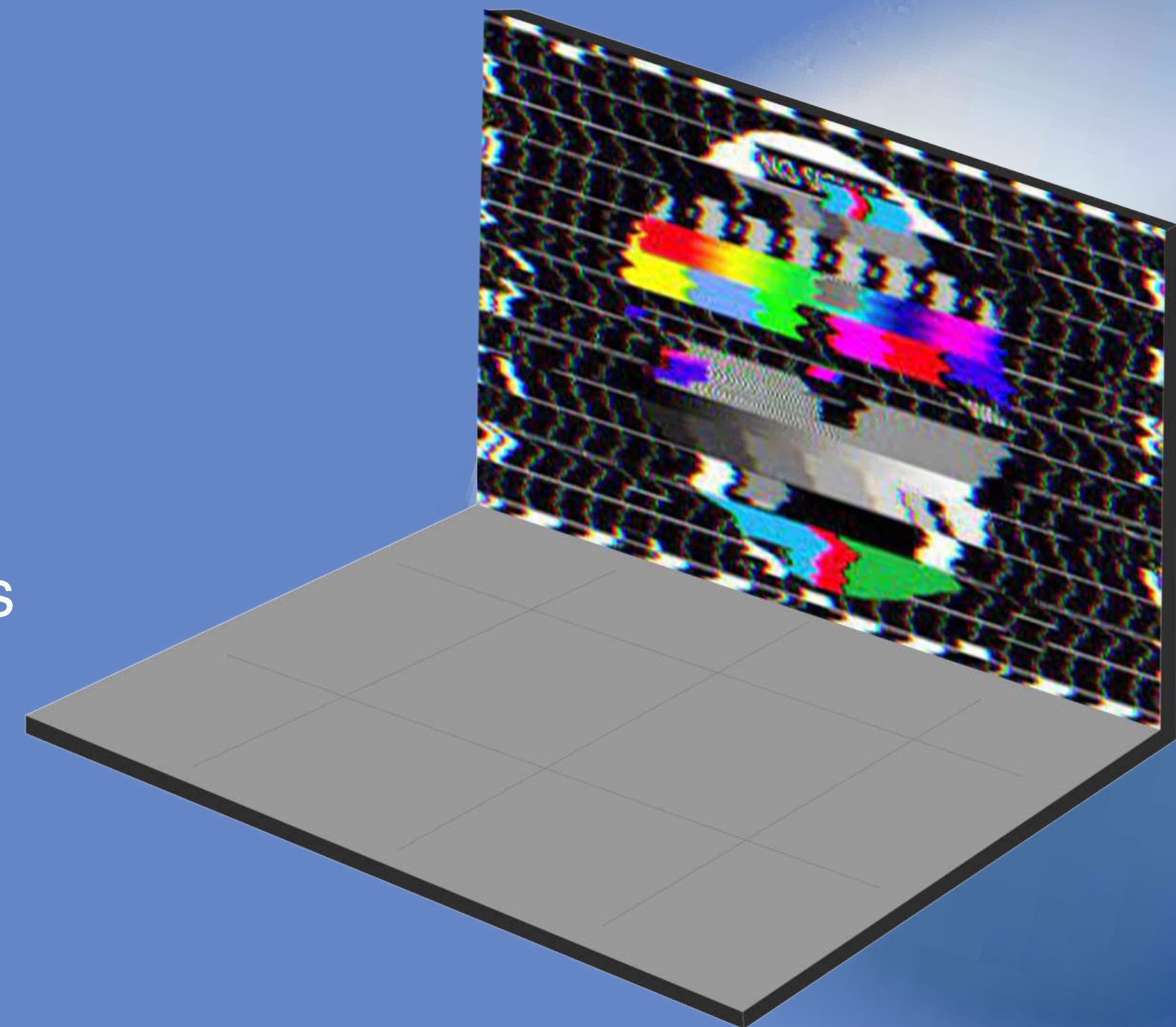

SWEET BAR:

BRANDED CRÊPE BAR / USD 6500

- 5 gold tickets for the team including
- 2 silver passes for affiliates
- A branded crêpe bar with customization of your brand, a wide selection of delicious pancakes, and a focal point for networking
- Logos on the press wall of the photozone
- Sponsorship announcement on the conference website + social media (audience of 60K+ marketers)

BRANDED WAFFLES BAR / USD 6500

- 5 gold tickets for the team including gold access to the afterparty
- 2 silver passes for affiliates
- A branded waffle bar with customization of your brand, a wide selection of delicious waffles, and a focal point of networking
- Logos on the press wall of the photo zone
- Sponsorship announcement on the conference website + social media (audience of 60K+ marketers)

BRANDED ICE-CREAM BAR / USD 6500

- 5 gold tickets for the team including
- 2 silver passes for affiliates
- A branded ice-cream bar with customization of your brand, a wide selection of delicious ice cream flavors, and a focal point of networking. Branded cups for ice-cream included.
- Logos on the press wall of the photozone
- Sponsorship announcement on the conference website + social media (audience of 60K+ marketers)

BRANDED WATER

BRANDED WATER

USD 6000



WHAT does this package offer?

- 5 gold tickets for the team including gold access to the afterparty
- 2 silver passes for affiliates
- Branded water bottles offer the customization of an essential product at a hot and bustling conference, providing a distinct and high-quality level of brand recognition among other brands at the event
- Logos on the press wall of the photo zone
- Sponsorship announcement on the conference website + social media (audience of 60K+ marketers)

FOOD ZONE SPONSOR

FOOD ZONE SPONSOR

USD 6000

WHAT does this package offer?

- 4 gold tickets for the team including gold access to the afterparty
- 2 silver passes for affiliates
- Big banner on a food counter
- 2 T-shirts with your logo on waiters
- Your business cards on Food Court zone
- Logos on Press Wall
- Sponsorship announcement on conference website + social media (audience of 60K+ marketers)



BADGE SPONSOR

BADGE SPONSOR

USD 5500



WHAT does this package offer?

- 5 tickets per team
- 5 basic passes to the official party
- Branded badges for all attendees of the Conference
- Logos on the press wall
- Sponsorship announcement on the conference website + social media (audience of 60K+ marketers)

HUMMER SPONSOR

HUMMER SPONSOR

USD 5000

WHAT does this package offer?

- 3 gold tickets for the team including gold access to the afterparty
- 2 silver passes for affiliates
- Branded Hummer with stickers 50x150 cm with your company logo
- Hummer will be located at the entrance to the conference hall for 2 days of the conference and will meet speakers at hotels
- Logos on Press Wall
- Sponsorship announcement on conference website + social media (audience of 60K+ marketers)



BRANDED OUTDOOR ENTRANCE SPONSOR

BRANDED OUTDOOR ENTRANCE SPON

USD 4900

LOGGO

WHAT does this package offer?

- 3 gold tickets for the team including gold access to the afterparty
- 2 silver passes for affiliates
- 10 branded flags for your company placed in front of conference area
- Logos on Press Wall
- Sponsorship announcement on conference website + social media (audience of 60K+ marketers)

EXTRA:



T-SHIRT SPONSOR / USD 3000

- Location coordinators in branded t-shirts with your company logo
- Sponsorship announcement on conference website + social media (audience of 60K+ marketers)

MESSAGE SPONSOR / USD 3000

- Branded massage area with your company logo
- Sponsorship announcement on conference website + social media (audience of 60K+ marketers)

CHARGING STATION SPONSOR / USD 3000

- 6 stickers (diameter 50 centimeters) with your company logo
- logo on 6 tables for charging and branded poufs
- Sponsorship announcement on conference website + social media (audience of 60K+ marketers)

ENTERTAINMENT SPONSOR / USD 3000

- Branded gaming machines (air hocke, etc.)
- 2 T-shirts with your company logo for staff members
- Sponsorship announcement on conference website + social media (audience of 60K+ marketers)

EXTRA:

COFFEE SPONSOR / USD 3000

- Your logo on the coffee machine and cups at the Conference
- Sponsorship announcement on the conference website + social media (audience of 60K+ marketers)

PHOTO BOOTH SPONSOR / USD 3000

- Photo booth with your logo on pictures at the Conference
- Sponsorship announcement on the conference website + social media (audience of 60K+ marketers)

EXTRA:

WI-FI SPONSOR / USD 3000

- Branded Wi-Fi password at the Conference
- Sponsorship announcement on the conference website + social media (audience of 60K+ marketers)

CUP SPONSOR / USD 3000

- Branded cups with your logo at the Conference
- Sponsorship announcement on the conference website + social media (audience of 60K+ marketers)



OFFICIAL AFTER PARTY SPONSORSHIP



GENERAL AFTER PARTY SPONSOR

GENERAL AFTER PARTY SPONSOR

USD 11900

WHAT does this package offer?

- 8 diamond tickets for the team including diamond access to the afterparty
- 4 silver passes for affiliates
- 10 large fly banners
- Branded private area exclusively for your company
- VIP table for team with luxury alcohol (rum, whiskey, wine, beer)
- Your logo on the video displayed on the LED-screen during the event
- Your logo on photos and video report from the party
- Sponsorship announcement on the conference website + social media (audience of 60K+ marketers)



DIAMOND AFTER PARTY SPONSOR

DIAMOND AFTER PARTY SPONSOR

USD 4900



WHAT does this package offer?

- 6 diamond tickets for the team including diamond access to the afterparty
- 2 silver passes for affiliates
- 2 X-banners 180*80 with your logo and QR code
- Branded VIP area
- VIP table for team with luxury alcohol (rum, whiskey, wine, beer)
- Your logo on the video displayed on the LED-screen during the event
- Your logo on photos and video report from the party
- Sponsorship announcement on the conference website + social media (audience of 60K+ marketers)



FOR ALL QUESTIONS REGARDING SPONSORSHIP,
VISA INVITATION, PRICES, AND OTHERS,
PLEASE SEND US A MESSAGE HERE:

CONTACT@CONVERSION-CLUB.COM
LANA.K@CONVERSION-CLUB.COM
SALES@CONVERSION-CLUB.COM

WEBSITE: <https://www.conversion-conf.com/>



KARYNA

HEAD OF SALES
@salescc2021



VLADIMIR

SALES
@conversion_conf_sales

LOUNGE SPONSOR

LOUNGE SPONSOR

USD 8000

WHAT does this package offer?

- 3 gold tickets for the team including gold access to the afterparty
- 2 silver passes for affiliates
- Branded lounge zone
- Your business cards on the tables of the Lounge Zone (upon your request)
- Logos on Press Wall
- Sponsorship announcement on conference website + social media (audience of 60K+ marketers)





THANK YOU FOR YOUR INTEREST

LOOKING FORWARD TO OUR LIVE CONFERENCE IN WARSAW IN 2024.
LET'S ROCK THE INDUSTRY TOGETHER AND GET
THE BEST UPDATES FROM OUR MARKETING GURUS!

THE MOST IMPORTANT THING IS TO HAVE
A GREAT TIME TOGETHER: LEARN, NETWORK, PARTY, RELAX, AND REPEAT

CONVERSION CLUB TEAM

